

ICC-ES Evaluation Report

ESR-1775

Reissued March 1, 2012

This report is subject to renewal in two years.www.icc-es.org | (800) 423-6587 | (562) 699-0543

A Subsidiary of the International Code Council®

**DIVISION: 07 00 00—THERMAL AND MOISTURE
PROTECTION**
Section: 07 32 16—CONCRETE ROOF TILES

REPORT HOLDER:

HANSON ROOF TILE, INC.
10650 POPLAR AVENUE
FONTANA, CALIFORNIA 92337-7334
(909) 350-4238
www.hansonrooftile.com

EVALUATION SUBJECT

**EXTRUDED INTERLOCKING CONCRETE ROOF TILES:
HACIENDA, HANSON FLAT, PROVENANCE FLAT,
REGAL AND VENETIAN**

1.0 EVALUATION SCOPE**Compliance with the following codes:**

- 2006 *International Building Code*® (IBC)
- 2006 *International Residential Code*® (IRC)

Properties evaluated:

- Fire classification
- Weather resistance
- Wind uplift resistance

2.0 USES

The Hanson extruded concrete roof tiles are used as Class A roof coverings in accordance with the exception to Section 1505.2 of the IBC or Section R902.1 of the IRC.

3.0 DESCRIPTION

These roof tiles are regular-weight extruded concrete roof tiles with interlocking ribs on the longitudinal edges of the tiles to restrict lateral movement and provide a water-stop. The roof tiles are designed with anchor lugs, and are manufactured from portland cement, sand, water and proprietary additives. Mineral coloring oxides are either applied to the exposed surface in a cementitious material or mixed integrally with the tile mix to produce a through-colored product. Ridge, rake and trim units are produced to match each tile profile. Refer to Table 1 for dimensions and installed weights. See Figures 1 through 5 for profile illustrations and Table 5 for tile factors.

4.0 INSTALLATION**4.1 General:**

The tiles must be installed, except as noted in this report, in accordance with the Concrete and Clay Roof Tile Installation Manual for Moderate Climate Regions,

published by the Tile Roofing Institute and the Western States Roofing Contractors Association (TRI/WSRCA), and recognized in [ESR-2015P](#). The TRI/WSRCA installation manual must be available at the jobsite at all times during installation.

4.2 Adhesively Attached Systems:

The Hanson extruded concrete roof tiles may be installed with roof tile adhesives that are recognized in a current ICC-ES evaluation report for use in concrete roof tile applications. Installation of tiles using these adhesively attached systems must be in accordance with the adhesive manufacturer's ICC-ES evaluation report.

4.3 Roof Slope Limitation:

Tiles must be installed on roof slopes of between 2¹/₂:12 (21 percent) and 21:12 (175 percent). Tiles may be installed at a roof slope greater than 21:12 when the bottom edge of each tile is secured with a roof tile clip or nail in accordance with the TRI/WSRCA installation manual.

4.4 Fire Classification:

When installed in accordance with this report, the Hanson extruded concrete roof tiles are Class A roof coverings in accordance with the exception to IBC Section 1505.2 and IRC Section R902.1.

4.5 Wind Uplift Resistance:

4.5.1 Mechanically Fastened Systems: For applications beyond the prescriptive parameters of IBC Table 1507.3.7 and IRC Section R905.3.7, the fastening systems must be designed to withstand the aerodynamic wind uplift moment. The required aerodynamic wind uplift moment must be determined in accordance with IBC Section 1609.5.3 or Tables 3 and 4 of this report.

The maximum allowable aerodynamic uplift moment for the roof tiles must be determined in accordance with Table 2. The fastening schedule chosen must be such that the allowable aerodynamic uplift moment for the roof tile/fastener/deck combination, noted in Table 2, exceeds the required aerodynamic uplift moment required by IBC Section 1609.5.3 or Tables 3 and 4 of this report.

4.5.2 Adhesively Attached Systems: See the adhesive manufacturer's ICC-ES evaluation report.

4.6 Reroofing Applications:

Mechanically fastened tiles may be installed over existing roofs, provided the requirements of IBC Section 1510 or IRC Section R907, as applicable, are met. The roof classification is as noted in Section 4.4.

5.0 CONDITIONS OF USE

The Hanson extruded concrete roof tiles described in this report comply with, or are suitable alternatives to what is specified in, those codes listed in Section 1.0 of this report, subject to the following conditions:

- 5.1 The tiles must be manufactured and identified in accordance with this report, and installed in accordance with this report, the applicable code, and the TRI/WSRCA installation manual. The instructions within this report govern if there are any conflicts between the installation manual and this report.
- 5.2 The roof sheathing and roof framing system must be designed for the appropriate loads determined in accordance with the applicable code, subject to the approval of the code official.

6.0 EVIDENCE SUBMITTED

Data in accordance with the ICC-ES Acceptance Criteria for Clay and Concrete Roof Tiles (AC180), dated August 2007.

7.0 IDENTIFICATION

The underside of each tile is imprinted with the name “Hanson” and the letter “H” or “Currier USA.” Each shipping pallet has a label bearing the manufacturer’s name (Hanson Roof Tile, Inc.), the manufacturing address, and the tile designation, color, product code number, production date, installed weight and the evaluation report number (ESR-1775).

TABLE 1—TILE DIMENSIONS, WEIGHTS, AND MANUFACTURING FACILITIES

REGULAR WEIGHT TILES				
TILE DESIGNATION	INSTALLED DRY WEIGHT (psf)	DIMENSIONS		MANUFACTURING FACILITY
		Length (inches)	Width (inches)	
Hacienda	9.1	17 ¹ / ₄	13	Deerfield Beach, FL Dixon, CA Hobe Sound, FL Fontana, CA Ft. Worth, TX Luling, TX Sanderson, FL Tolleson, AZ
Hanson Flat	9.5 – 10.5	17 ¹ / ₄	13	Deerfield Beach, FL Dixon, CA Fontana, CA Ft. Worth, TX Luling, TX Sanderson, FL Tolleson, AZ
Provenance Flat	12.5	14 ³ / ₄	9 ³ / ₄	Fontana, CA
Regal	9.9	17 ¹ / ₄	13 ¹ / ₄	Deerfield Beach, FL Dixon, CA Fontana, CA Ft. Worth, TX Luling, TX Sanderson, FL Tolleson, AZ
Venetian	9.9	16 ¹ / ₂	13	Fort Myers, FL

For **SI**: 1 inch = 25.4 mm, 1 ft-lbf = 1.356 Nm.

TABLE 2—ALLOWABLE AERODYNAMIC UPLIFT MOMENT (ft-lb)

FASTENERS	PROVENANCE FLAT AND VENETIAN			HACIENDA, HANSON FLAT, AND REGAL		
	Sheathing		Batten	Sheathing		Batten
	¹⁵ / ₃₂ inch	⁵ / ₈ inch		¹⁵ / ₃₂ inch	⁵ / ₈ inch	
2-10d Ring Shank Nails	39	46	25	36	46	36
1-#8 Screw	39	39	26	33	33	30
2-#8 Screws	50	50	36	56	56	42
1-10d Smooth or Screw Shank Nails	14	16	10	13	15	9
2-10d Smooth or Screw Shank Nails	20	25	13	19	24	12
1-10d Smooth or Screw Shank Nails – Field Clip	31	31	30	31	31	30
1-10d Smooth or Screw Shank Nails – Eave Clip	25	25	28	25	25	28
2-10d Smooth or Screw Shank Nails – Field Clip	42	42	40	42	42	40
2-10d Smooth or Screw Shank Nails – Eave Clip	38	38	38	38	38	38

For SI: 1 inch = 25.4 mm, 1 ft-lbf = 1.356 Nm.

Notes:

- ¹Sheathing is wood structural panels, plywood or oriented strand board (OSB).
- ²Fasteners must have a minimum edge distance of 1 1/2 inch from the tile's head.
- ³Ring shank nails must be 10d ring shank corrosion resistant steel with the following minimum dimensions: 3 inches (76 mm) long, 0.283-inch (7.19 mm) flat head diameter, 0.120-inch (3.07 mm) undeformed shank diameter, and 0.131-inch (3.33 mm) ring diameter].
- ⁴Smooth or screw shank nails must be 10d corrosion resistant steel with the following minimum dimensions: 3 inches (76 mm) long, 0.283-inch flat head diameter (7.19 mm), 0.120-inch (3.07 mm) undeformed shank diameter, and 0.131-inch (3.33 mm) ring diameter.
- ⁵Screws must be #8 coarse-threaded, minimum 2 1/2-inch long (63.5 mm) corrosion resistant steel wood screws conforming to ANSI/ASME B 18.6.1.
- ⁶When using eave and field clips, the tiles are attached using a combination of fasteners and clips. Tiles must be fastened to the sheathing or through the battens to the sheathing with one of the fastener systems indicated in the table. Additionally, each tile must be secured with a 0.060-inch-thick (1.52 mm) and 0.5-inch-wide (12.7 mm) clip which is secured to the wood structural panel sheathing or eave fascia, as appropriate, with a single fastener per clip. For clips having more than one fastener hole, place the fastener in the innermost fastener hole (the one closest to the upright leg of the clip). The following clip/fastener combinations must be used:
 - (1) Aluminum alloy clip with 1.25 inch (31.75 mm) hot dipped galvanized roofing nail [0.128-inch (3.25 mm) shank diameter].
 - (2) Galvanized steel deck clip with 1.25-inch hot dipped galvanized roofing nail [0.128-inch (3.25 mm) shank diameter].
 - (3) Stainless steel clip with 1.25-inch hot dipped galvanized roofing nail [0.128-inch (3.25 mm) shank diameter].
- ⁷Field clips and eave clips are to be located along the tile where the clip's preformed height and the tile's height above the underlayment are identical.
- ⁸For roof tile eave clips, the clip position is appropriate for a 3/4 inch (19.05 mm) to 2 inches (51 mm) overhang at the eaves.

TABLE 3—REQUIRED AERODYNAMIC UPLIFT MOMENTS, M_a (ft-lbf) for EXPOSURE B
TABLE 3A

AERODYNAMIC UPLIFT MOMENT, M _a (ft-lbf) FOR TILE FACTOR 1.407 ft ³ EXPOSURE B GABLE ≤ 6.5:12 (28.4°) HIP 5.5:12 (24.6°) < θ ≤ 6.5:12 (28.4°)											
Height (ft)	Basic Wind Speed, V (mph)										
	85	90	100	105	110	120	125	130	140	145	150
Importance Factor = 1.00											
0-30	11.2	12.5	15.4	17.0	18.7	22.2	24.1	26.1	30.3	32.5	34.7
40	12.1	13.6	16.8	18.5	20.3	24.1	26.2	28.3	32.9	35.3	37.7
50	12.9	14.5	17.9	19.7	21.6	25.7	27.9	30.2	35.0	37.6	40.2
60	13.6	15.2	18.8	20.8	22.8	27.1	29.4	31.8	36.9	39.6	42.4
Importance Factor = 1.15											
0-30	12.8	14.4	17.8	19.6	21.5	25.6	27.7	30.0	34.8	37.3	40.0
40	13.9	15.6	19.3	21.3	23.3	27.8	30.1	32.6	37.8	40.5	43.4
50	14.8	16.6	20.6	22.7	24.9	29.6	32.1	34.7	40.3	43.2	46.2
60	15.6	17.5	21.6	23.9	26.2	31.2	33.8	36.6	42.4	45.5	48.7

For SI: 1 inch = 25.4 mm, 1 ft-lbf = 1.356 Nm.

TABLE 3B

AERODYNAMIC UPLIFT MOMENT, M_a (ft-lbf) FOR TILE FACTOR 1.407 ft ³ EXPOSURE B											
HIP $\theta \leq 5.5:12$ (24.6°)											
Height (ft)	Basic Wind Speed, V (mph)										
	85	90	100	105	110	120	125	130	140	145	150
Importance Factor = 1.00											
0-30	8.4	9.4	11.6	12.8	14.0	16.7	18.1	19.6	22.7	24.4	26.1
40	9.1	10.2	12.6	13.9	15.2	18.1	19.6	21.3	24.6	26.4	28.3
50	9.7	10.9	13.4	14.8	16.2	19.3	20.9	22.6	26.3	28.2	30.2
60	10.2	11.4	14.1	15.6	17.1	20.3	22.1	23.9	27.7	29.7	31.8
Importance Factor = 1.15											
0-30	9.6	10.8	13.3	14.7	16.1	19.2	20.8	22.5	26.1	28.0	30.0
40	10.4	11.7	14.5	15.9	17.5	20.8	22.6	24.4	28.3	30.4	32.5
50	11.1	12.5	15.4	17.0	18.6	22.2	24.1	26.0	30.2	32.4	34.7
60	11.7	13.2	16.2	17.9	19.6	23.4	25.4	27.4	31.8	34.1	36.5

For SI: 1 inch = 25.4 mm, 1 ft-lbf = 1.356 Nm.

TABLE 3C

AERODYNAMIC UPLIFT MOMENT, M_a (ft-lbf) FOR TILE FACTOR 1.407 ft ³ EXPOSURE B											
GABLE 6.5:12 (28.4°) < $\theta \leq 12:12$ (45°)											
Height (ft)	Basic Wind Speed, V (mph)										
	85	90	100	105	110	120	125	130	140	145	150
Importance Factor = 1.00											
0-30	6.8	7.6	9.4	10.4	11.4	13.6	14.7	15.9	18.5	19.8	21.2
40	7.4	8.3	10.2	11.3	12.4	14.8	16.0	17.3	20.1	21.5	23.1
50	7.9	8.8	10.9	12.0	13.2	15.7	17.1	18.5	21.4	23.0	24.6
60	8.3	9.3	11.5	12.7	13.9	16.6	18.0	19.4	22.5	24.2	25.9
Importance Factor = 1.15											
0-30	7.8	8.8	10.9	12.0	13.1	15.6	17.0	18.3	21.3	22.8	24.4
40	8.5	9.5	11.8	13.0	14.3	17.0	18.4	19.9	23.1	24.8	26.5
50	9.1	10.2	12.6	13.8	15.2	18.1	19.6	21.2	24.6	26.4	28.3
60	9.6	10.7	13.2	14.6	16.0	19.1	20.7	22.4	25.9	27.8	29.8

For SI: 1 inch = 25.4 mm, 1 ft-lbf = 1.356 Nm.

TABLE 3D

AERODYNAMIC UPLIFT MOMENT, M_a (ft-lbf) FOR TILE FACTOR 1.407 ft ³ EXPOSURE B											
MONOSLOPE 2 ¹ / ₂ :12 (11.8°) < $\theta \leq 7:12$ (30.2°)											
Height (ft)	Basic Wind Speed, V (mph)										
	85	90	100	105	110	120	125	130	140	145	150
Importance Factor = 1.00											
0-30	12.1	13.6	16.7	18.4	20.2	24.1	26.1	28.3	32.8	35.2	37.6
40	13.1	14.7	18.2	20.0	22.0	26.2	28.4	30.7	35.6	38.2	40.9
50	14.0	15.7	19.4	21.3	23.4	27.9	30.2	32.7	37.9	40.7	43.6
60	14.7	16.5	20.4	22.5	24.7	29.4	31.9	34.5	40.0	42.9	45.9
Importance Factor = 1.15											
0-30	13.9	15.6	19.2	21.2	23.3	27.7	30.1	32.5	37.7	40.5	43.3
40	15.1	16.9	20.9	23.0	25.3	30.1	32.6	35.3	40.9	43.9	47.0
50	16.1	18.0	22.3	24.5	26.9	32.1	34.8	37.6	43.6	46.8	50.1
60	16.9	19.0	23.5	25.9	28.4	33.8	36.6	39.6	46.0	49.3	52.8

For SI: 1 inch = 25.4 mm, 1 ft-lbf = 1.356 Nm.

Notes:

¹Required aerodynamic uplift moments in Table 3 are based on a tile factor of 1.407 (ft³).

²The use of the required aerodynamic uplift moments in Table 3 is conservative for the Hacienda, Hanson Flat, Provenance Flat and Venetian tiles. To calculate the exact required aerodynamic uplift moments for one of these tile multiply the required aerodynamic uplift moments from Table 3 by the Tile Ratio Factor in Table 5 for that specific tile.

**TABLE 4—REQUIRED AERODYNAMIC UPLIFT MOMENTS, M_a (ft-lbf) for EXPOSURE C
TABLE 4A**

AERODYNAMIC UPLIFT MOMENT, M_a (ft-lbf) FOR TILE FACTOR 1.407 ft ³ EXPOSURE C GABLE $\theta \leq 6.5:12$ (28.4°) HIP 5.5:12 (24.6°) < $\theta \leq 6.5:12$ (28.4°)											
Height (ft)	Basic Wind Speed, V (mph)										
	85	90	100	105	110	120	125	130	140	145	150
Importance Factor = 1.00											
0-15	13.5	15.2	18.7	20.6	22.6	26.9	29.2	31.6	36.7	39.3	42.1
20	14.4	16.1	19.9	21.9	24.1	28.6	31.1	33.6	39.0	41.8	44.7
25	15.1	16.9	20.8	23.0	25.2	30.0	32.6	35.2	40.8	43.8	46.9
30	15.6	17.5	21.7	23.9	26.2	31.2	33.8	36.6	42.4	45.5	48.7
40	16.6	18.6	23.0	25.4	27.8	33.1	35.9	38.9	45.1	48.4	51.8
50	17.4	19.5	24.1	26.6	29.2	34.7	37.7	40.7	47.3	50.7	54.2
60	18.1	20.3	25.1	27.6	30.3	36.1	39.1	42.3	49.1	52.7	56.4
Importance Factor = 1.15											
0-15	15.5	17.4	21.5	23.7	26.0	31.0	33.6	36.4	42.2	45.2	48.4
20	16.5	18.5	22.9	25.2	27.7	32.9	35.7	38.6	44.8	48.1	51.4
25	17.3	19.4	24.0	26.4	29.0	34.5	37.4	40.5	47.0	50.4	53.9
30	18.0	20.2	24.9	27.5	30.1	35.9	38.9	42.1	48.8	52.4	56.0
40	19.1	21.4	26.5	29.2	32.0	38.1	41.3	44.7	51.8	55.6	59.5
50	20.0	22.5	27.7	30.6	33.5	39.9	43.3	46.9	54.3	58.3	62.4
60	20.8	23.3	28.8	31.8	34.9	41.5	45.0	48.7	56.5	60.6	64.8

For SI: 1 inch = 25.4 mm, 1 ft-lbf = 1.356 Nm.

TABLE 4B

AERODYNAMIC UPLIFT MOMENT, M_a (ft-lbf) FOR TILE FACTOR 1.407 ft ³ EXPOSURE C HIP $\theta \leq 5.5:12$ (24.6°)											
Height (ft)	Basic Wind Speed, V (mph)										
	85	90	100	105	110	120	125	130	140	145	150
Importance Factor = 1.00											
0-15	10.1	11.4	14.0	15.5	17.0	20.2	21.9	23.7	27.5	29.5	31.6
20	10.8	12.1	14.9	16.4	18.0	21.5	23.3	25.2	29.2	31.3	33.5
25	11.3	12.7	15.6	17.2	18.9	22.5	24.4	26.4	30.6	32.9	35.2
30	11.7	13.2	16.2	17.9	19.6	23.4	25.4	27.4	31.8	34.1	36.5
40	12.5	14.0	17.3	19.0	20.9	24.8	27.0	29.2	33.8	36.3	38.8
50	13.1	14.6	18.1	19.9	21.9	26.0	28.3	30.6	35.4	38.0	40.7
60	13.6	15.2	18.8	20.7	22.7	27.1	29.4	31.8	36.8	39.5	42.3
Importance Factor = 1.15											
0-15	11.7	13.1	16.1	17.8	19.5	23.2	25.2	27.3	31.6	33.9	36.3
20	12.4	13.9	17.1	18.9	20.7	24.7	26.8	29.0	33.6	36.1	38.6
25	13.0	14.6	18.0	19.8	21.7	25.9	28.1	30.4	35.2	37.8	40.4
30	13.5	15.1	18.7	20.6	22.6	26.9	29.2	31.6	36.6	39.3	42.0
40	14.3	16.1	19.8	21.9	24.0	28.6	31.0	33.5	38.9	41.7	44.6
50	15.0	16.8	20.8	22.9	25.2	29.9	32.5	35.1	40.8	43.7	46.8
60	15.6	17.5	21.6	23.8	26.1	31.1	33.8	36.5	42.4	45.4	48.6

For SI: 1 inch = 25.4 mm, 1 ft-lbf = 1.356 Nm.

TABLE 4C

AERODYNAMIC UPLIFT MOMENT, M_a (ft-lbf) FOR TILE FACTOR 1.407 ft ³ EXPOSURE C GABLE 6.5:12 (28.4°) < θ ≤ 12:12 (45°)											
Height (ft)	Basic Wind Speed, V (mph)										
	85	90	100	105	110	120	125	130	140	145	150
Importance Factor = 1.00											
0-15	8.3	9.3	11.4	12.6	13.8	16.5	17.9	19.3	22.4	24.0	25.7
20	8.8	9.8	12.1	13.4	14.7	17.5	19.0	20.5	23.8	25.5	27.3
25	9.2	10.3	12.7	14.0	15.4	18.3	19.9	21.5	25.0	26.8	28.6
30	9.6	10.7	13.2	14.6	16.0	19.1	20.7	22.4	25.9	27.8	29.8
40	10.2	11.4	14.1	15.5	17.0	20.2	22.0	23.8	27.6	29.6	31.6
50	10.6	11.9	14.7	16.2	17.8	21.2	23.0	24.9	28.9	31.0	33.2
60	11.1	12.4	15.3	16.9	18.5	22.0	23.9	25.9	30.0	32.2	34.4
Importance Factor = 1.15											
0-15	9.5	10.7	13.2	14.5	15.9	18.9	20.5	22.2	25.8	27.6	29.6
20	10.1	11.3	14.0	15.4	16.9	20.1	21.8	23.6	27.4	29.4	31.4
25	10.6	11.9	14.6	16.1	17.7	21.1	22.9	24.7	28.7	30.8	32.9
30	11.0	12.3	15.2	16.8	18.4	21.9	23.8	25.7	29.8	32.0	34.2
40	11.7	13.1	16.2	17.8	19.6	23.3	25.3	27.3	31.7	34.0	36.4
50	12.2	13.7	16.9	18.7	20.5	24.4	26.5	28.6	33.2	35.6	38.1
60	12.7	14.3	17.6	19.4	21.3	25.4	27.5	29.8	34.5	37.0	39.6

For SI: 1 inch = 25.4 mm, 1 ft-lbf = 1.356 Nm.

TABLE 4D

AERODYNAMIC UPLIFT MOMENT, M_a (ft-lbf) FOR TILE FACTOR 1.407 ft ³ EXPOSURE C MONOSLOPE 2 ¹ / ₂ :12 (11.8°) < θ ≤ 7:12 (30.2°)											
Height (ft)	Basic Wind Speed, V (mph)										
	85	90	100	105	110	120	125	130	140	145	150
Importance Factor = 1.00											
0-15	14.6	16.4	20.3	22.3	24.5	29.2	31.7	34.3	39.7	42.6	45.6
20	15.6	17.4	21.5	23.7	26.1	31.0	33.7	36.4	42.2	45.3	48.5
25	16.3	18.3	22.6	24.9	27.3	32.5	35.3	38.1	44.2	47.5	50.8
30	16.9	19.0	23.5	25.9	28.4	33.8	36.6	39.6	46.0	49.3	52.8
40	18.0	20.2	24.9	27.5	30.2	35.9	38.9	42.1	48.8	52.4	56.1
50	18.9	21.2	26.1	28.8	31.6	37.6	40.8	44.1	51.2	54.9	58.8
60	19.6	22.0	27.1	29.9	32.8	39.1	42.4	45.9	53.2	57.1	61.1
Importance Factor = 1.15											
0-15	16.8	18.9	23.3	25.7	28.2	33.6	36.4	39.4	45.7	49.0	52.5
20	17.9	20.1	24.8	27.3	30.0	35.7	38.7	41.9	48.5	52.1	55.7
25	18.8	21.0	26.0	28.6	31.4	37.4	40.6	43.9	50.9	54.6	58.4
30	19.5	21.8	27.0	29.7	32.6	38.8	42.1	45.6	52.9	56.7	60.7
40	20.7	23.2	28.7	31.6	34.7	41.3	44.8	48.4	56.2	60.3	64.5
50	21.7	24.3	30.0	33.1	36.3	43.3	46.9	50.8	58.9	63.2	67.6
60	22.6	25.3	31.2	34.4	37.8	44.9	48.8	52.7	61.2	65.6	70.2

For SI: 1 inch = 25.4 mm, 1 ft-lbf = 1.356 Nm.

Notes:

¹Required aerodynamic uplift moments in Table 3 are based on a tile factor of 1.407 (ft³).

²The use of the required aerodynamic uplift moments in Table 4 is conservative for the Hacienda, Hanson Flat, Provenance Flat and Venetian tiles. To calculate the exact required aerodynamic uplift moments for one of these tile multiply the required aerodynamic uplift moments from Table 3 by the Tile Ratio Factor in Table 5 for that specific tile.

TABLE 5—TILE FACTORS

TILE DESIGNATION	DIMENSIONS			TILE FACTOR (ft ³)	TILE RATIO FACTOR
	LENGTH (inches)	WIDTH			
		Total (inches)	Exposed (inches)		
Hacienda	17 ¹ / ₄	13	11 ³ / ₄	1.538	1.093
Hanson Flat	17 ¹ / ₄	13	12 ¹ / ₈	1.587	1.128
Provenance Flat	14 ³ / ₄	9 ³ / ₄	8 ¹ / ₂	0.813	0.578
Regal	17 ¹ / ₄	13 ¹ / ₄	11 ³ / ₄	1.538	1.093
Venetian	16 ¹ / ₂	13	11 ³ / ₄	1.407	1.000

For SI: 1 inch = 25.4 mm, 1 ft-lbf = 1.356 Nm.

Notes:

¹The interlocking sidelap for the Hacienda, Provenance Flat and Venetian is 1⁵/₁₆ inch.

²The interlocking sidelap for the Regal is 1¹/₂ inch.

³The interlocking sidelap for the Hanson Flat is 3³/₄ inch.

⁴The tile adjustment factors are referenced to a tile factor of 1.407 (ft³).

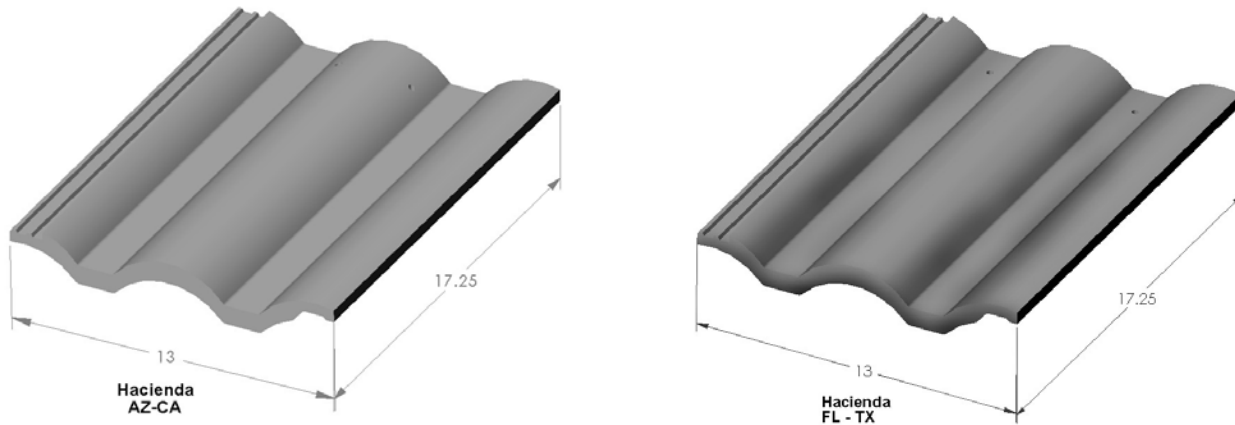
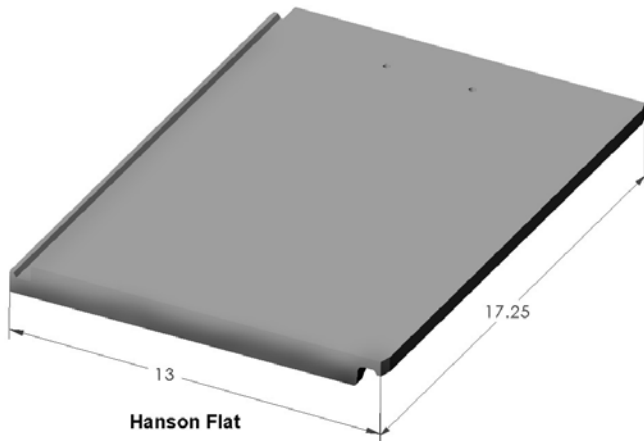
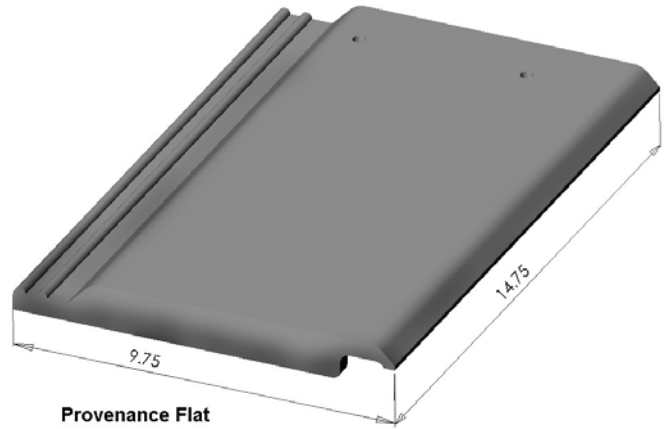

FIGURE 1—HACIENDA TILES



Hanson Flat

FIGURE 2—HANSON



Provenance Flat

FIGURE 3—PROVENANCE FLAT

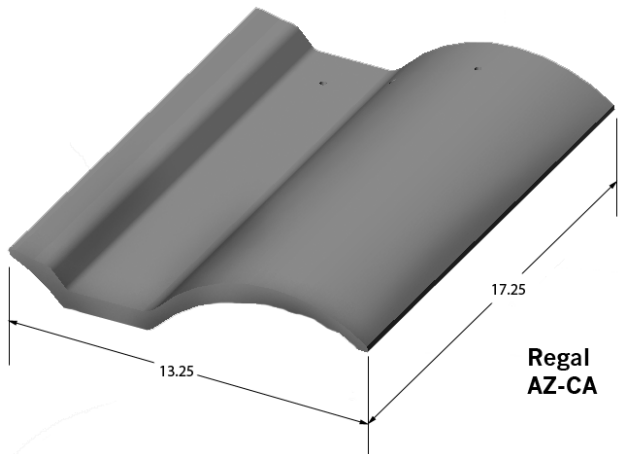

Regal
AZ-CA

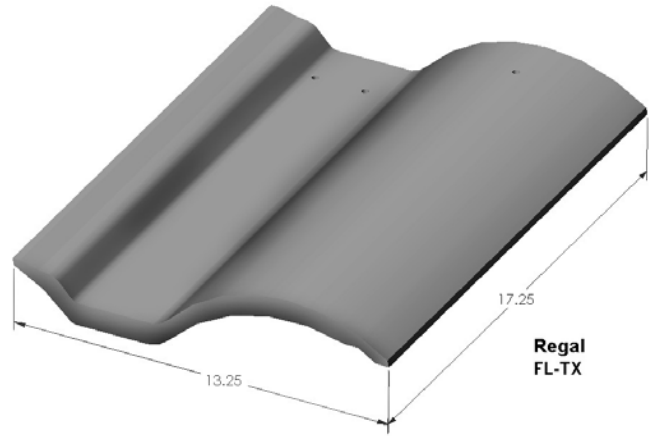

Regal
FL-TX

FIGURE 4—REGAL TILES

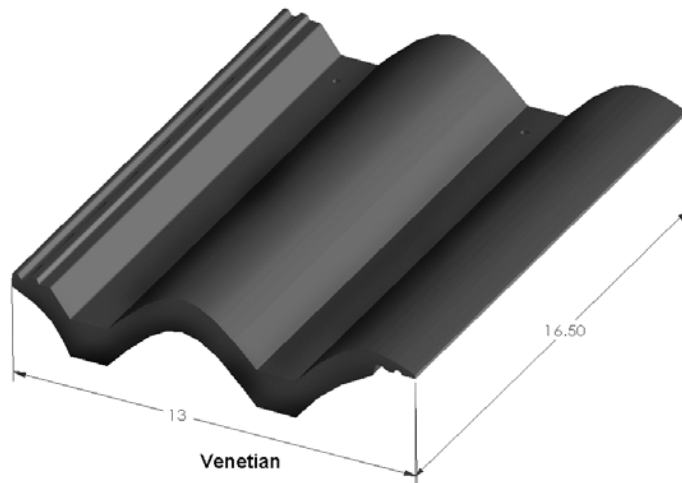

Venetian

FIGURE 5—VENETIAN

ICC-ES Evaluation Report**ESR-1775 Supplement**

Reissued March 1, 2012

This report is subject to renewal in two years.

www.icc-es.org | (800) 423-6587 | (562) 699-0543 A Subsidiary of the International Code Council®

DIVISION: 07 00 00—THERMAL AND MOISTURE PROTECTION
Section: 07 32 16—Concrete Roof Tiles**REPORT HOLDER:****HANSON ROOF TILE, INC.**
10650 POPLAR AVENUE
FONTANA, CALIFORNIA 92337-7334
(909) 350-4238
www.hansonrooftile.com**EVALUATION SUBJECT:****EXTRUDED INTERLOCKING CONCRETE ROOF TILES:
HACIENDA, HANSON FLAT, PROVENANCE FLAT, REGAL AND VENETIAN****1.0 EVALUATION SCOPE****Compliance with the following codes:**

- 2007 Florida Building Code—Building
- 2007 Florida Building Code—Residential

Properties Evaluated:

- Fire classification
- Weather resistance

Wind uplift resistance

2.0 PURPOSE OF THIS SUPPLEMENT

This supplement is issued to indicate that the extruded concrete roof tiles described in Sections 2.0 through 7.0 and in Tables 1 through 5 of the master report comply with the 2007 Florida Building Code—Building and the 2007 Florida Building Code—Residential, when designed and installed in accordance with the master evaluation report under this additional condition:

The Hanson extruded concrete roof tiles must be installed in accordance with the recommendations of the FRSA/TRI 07320 Installation Manual.

Use of the concrete roof tiles described in the master evaluation report for compliance with the High-Velocity Hurricane Zone provisions of the 2007 Florida Building Code—Building, and the 2007 Florida Building Code—Residential has not been evaluated, and is outside the scope of this supplement.

For products falling under Florida Rule 9B-72, verification that the report holder's quality assurance program is audited by a quality assurance entity approved by the Florida Building Commission for the type of inspections being conducted is the responsibility of an approved validation entity (or the code official when the report holder does not possess an approval by the Commission).

This supplement expires concurrently with the master report reissued on March 1, 2012.